

DEPENDAPOWER Transportable Pumps

Description

WILLIAMS FIRE & HAZARD CONTROL (WILLIAMS) DEPENDAPOWER Transportable Pumps incorporate a diesel-driven horizontal split case centrifugal pump and utilize a premium CATERPILLAR* diesel driver and water pump. The versatile 6000 Model delivers exceptional performance with a 10 ft (3.05 m) lift of 6,000 gpm (22,712 Lpm) rating at 150 psi (10.3 bar) net outlet pressure at sea level.

Rugged corrosion-resistant designs, including full stainless steel manifolds and internal ceramic pump coating, produce an ideal system for draft and relay pump operations with fresh water, sea water, or brackish water. The pump, driver, and built-in fuel cell are integrated on a modular independent skid. The skid can be incorporated into various transportation modes, such as trailers or hook load skids to provide additional mobility.

The DEPENDAPOWER line of pumps offers standard configurations built with popular features to get you up and running fast. This includes an extensive list of optional items, accessories, and pump sizes that provide great flexibility in customizing a pump solution that will meet your most challenging water management needs.

Features

Wide Range of Available Packages: Available in 1,500 gpm (5,678 Lpm), 4,000 gpm (15,142 Lpm), 6,000 gpm (22,712 Lpm), and 8,000 gpm (30,283 Lpm) packages.

Global Emissions Compliance: DEPENDAPOWER Pumps offer global emissions compliance with Tier II, III, and IV drivers.

Reliable Proven Track Record: These pump packages have been deployed by WILLIAMS Emergency Response Services for decades in their extensive, global response efforts. DEPENDAPOWER pump configurations are a critical component of our Emergency Response and Equipment Rental services.

Ease of Use and Serviceability: These packages offer a user-friendly operations interface, as well as low maintenance requirements. Typical field maintenance issues, such as fuel, oil, and filters, are minimal. Service partners are available globally for driver or service pump needs.

World Class Components: Superior performance of 10 ft (3.05 m) lift at full flow rate enables direct drafting from low level water sources where competing products fall short. Pumps provide lift as high as 20 ft (6.1 m) with reduced flow and proper priming.

Designed for Mobility: Compatible with various transportation modes, these pumps provide a great deal of power in a portable package. They offer mobility and stability for deployment into any land or marine based exercise.

Wide Range of Available Options: Meet today's most challenging water movement scenarios with a fully customizable pump package tailored to your unique specifications.

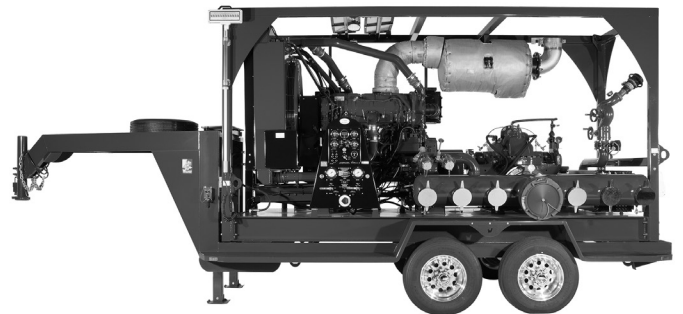

009939

Optional Features

- 12 V electric front and rear jacks with trailer mounted battery (trailer mounted only)
- Suction and supply hose racks
- Toolbox
- Onboard monitor
- Double mechanical seals, API Plan 53 flush, with tank
- Twin-disc clutch and hydraulic actuation kit with air-powered dry prime type system
- Sound attenuated pump enclosure
- Collapsible awning over operator area
- Configurable with bumper-pull or gooseneck-styled trailer, or hook-load skid configurations

Note: Contact Johnson Controls customer service for additional custom configurations.

Application

The adequate supply and management of water resources are critical to the success of any firefighting emergency response effort. Whether drafting from natural water sources or feeding off a facility's positive pressure water system, relaying water over miles of hose can be challenging.

WILLIAMS DEPENDAPOWER product line is a customizable, high-performance offering with three primary pump size options. Field-proven, these workhorse pumps have demonstrated they are built to run tirelessly, sustain high pressure, and deliver the large water volumes required for the most challenging industrial firefighting scenarios.

Technical Specifications

Standard Base Skid Features	
Base Material	Carbon steel
Skid Nominal Dimensions (H x W x L)¹	174 in. x 64 in. x 10 in. (4,419.6 mm x 1,625.6 mm x 254 mm)
Skid Gross Weight (with fuel)²	16,600 lb (7,530 kg)
Standard Platform	Skid style template: Skid offers pick-and-place flexibility, and fits all WILLIAMS trailer layout options.
Pump Model	GOULDS* 14 x 10
Pump Type	Horizontal split-case
Pump Coating	Ceramic coating / Internal pump case
Driver	CATERPILLAR
Fuel Cell Capacity	420 gal (1,590 L)
Standard Suction Inlets²	6 in. x 6 in. (M)NST, 2 in. x 2.5 in. (F)NST with caps; other options available
Suction Hose	6 each 6 in. x 20 ft Suction Hoses are included in base cost
Standard Discharge Outlets²	6 in. x 6 in. Storz couplings, 2 in. x 2.5 in. (M)NST with caps; other options available
Control Panel	Digital control panel with Automatic Pressure Governor, offering full-functional output monitoring
Light Packs	24 V LED movable hinged lights mounted to lifting frame for positioning over work area and for pump maintenance.

Performance Features			
	1,500 gpm (5,678 Lpm) unit	6,000 gpm (22,700 Lpm) unit	8,000 gpm (30,200 Lpm) unit
Maximum Run time with Full Tank	6 hours per tank of fuel	11 hours per tank of fuel	11 hours per tank of fuel
Flow Rate with 10 ft (3.05 m) Lift	150 psi (10.3 bar) net: 1,500 gpm (5,678 Lpm)	150 psi (10.3 bar) net: 1,500 gpm (5,678 Lpm)	150 psi (10.3 bar) net: 8,000 gpm (30,200 Lpm) ³
		170 psi (11.7 bar) net: 5,000 gpm (18,900 Lpm)	170 psi (11.7 bar) net: 6,600 gpm (24,900 Lpm)
		190 psi (13.1 bar) net: 4,000 gpm (15,100 Lpm)	190 psi (13.1 bar) net: 6,000 gpm (22,700 Lpm)

Environmental and Safety Features	
Maximum Ambient Temperature	120 °F (49 °C) ⁴
Protection System	Emergency kill switch: auxiliary circuit breaker bank
Standard Items included (unless otherwise specified)	All inlet manifolds also include 2 each 2 1/2 in. app style ball valve auxiliary inlets and 1 in. x 3 in. blind flange for optional equipment.
	All discharge manifolds also include 2 each 2 1/2 in. app style ball valve auxiliary discharge outlets and 1 in. x 3 in. blind flange for optional equipment.
	Suction hoses: 6 each 6 in. x 20 ft suction hose
	Strainers: 6 each 6 in. NST barrel strainers

- Notes:**
1. Only applies to standard units. May change with options.
 2. Customized units are available upon request.
 3. 6 ft (1.8 m) lift.
 4. Options available for severe ambient temperatures.

Note: The converted metric values in this document are provided for dimensional reference only and do not reflect an actual measurement.

Note: US EPA Tier II, Tier III, and Tier IV Emissions Compliance available as required by region.

*CATERPILLAR and GOULDS are trademarks of their respective owners.

WILLIAMS FIRE & HAZARD CONTROL, DEPENDAPOWVER, and the product names listed in this material are marks and/or registered marks. Unauthorized use is strictly prohibited.